

Important!

- Read the entire Afinion™ ACR Quick Guide before testing patient samples or controls.
- See the Afinion™ AS100 Analyzer User Manual for more information about the operation of the Analyzer and Test Cartridge.
- See the Afinion™ ACR Package Insert for more information about the ACR assay.
- Use quality control materials to confirm that the Analyzer and test kit are working properly.

1 Getting Started

Take time to familiarize yourself with the Analyzer and the test kit.

Afinion™ AS100 Analyzer

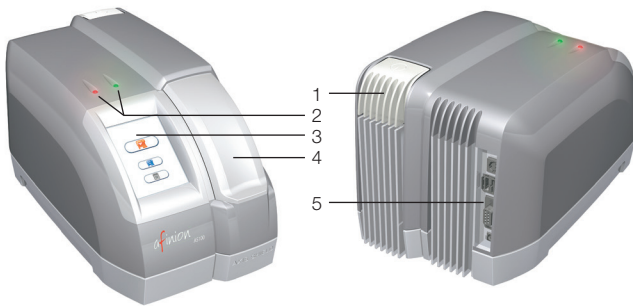







- 1 ON/OFF button
- 2 Light emitting diodes
- 3 Touch screen
- 4 The lid
- 5 Connectors

Cleaning the Analyzer

Clean the Analyzer every 30 days. Follow the procedure in the User Manual. See section “Cleaning and Maintenance”.

Important Touch Buttons

-  Patient sample mode
-  Control mode
-  Patient ID
-  Control ID
-  Enter
-  Accept

Important Information Codes

Code	Cause
107	Creatinine too high
108	Blood in the urine detected by the Analyzer*
213	Test Cartridge or Analyzer failure

* see Afinion™ ACR Package Insert

If the patient's albumin and/or creatinine value is outside the reportable range, one or two of the messages in the list below will be displayed. In this case an ACR test result will not be reported, and the last message listed below (ACR: - - -) will be displayed.

Symbol	Cause/Explanation
Albumin: < 5.0 mg/L	The albumin concentration is below 5.0 mg/L
Albumin: > 200.0 mg/L	The albumin concentration is above 200.0 mg/L
Creatinine: < 16.4 mg/dL	The creatinine concentration is below 16.4 mg/dL
Creatinine: > 339.9 mg/dL	The creatinine concentration is above 339.9 mg/dL
ACR: - - -	The ACR value cannot be calculated as the albumin or creatinine value is outside range.

Afinion™ ACR Test Cartridge

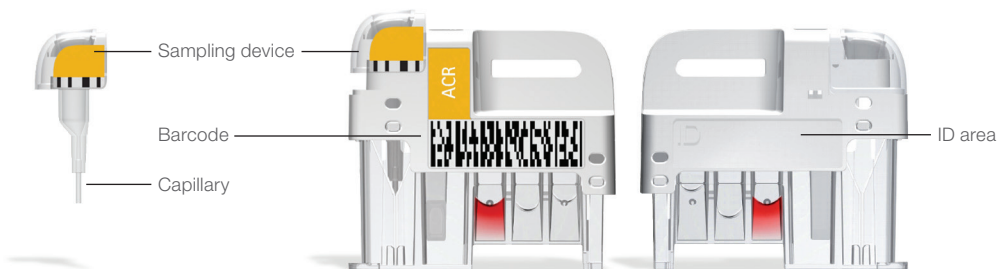

2 Prepare for Testing

- Switch the Analyzer on.
- Allow 15 minutes for the Test Cartridge to reach operating temperature 20-30°C (64-86°F) before use.
- Open the pouch just before use. Hold the Test Cartridge by the handle.
- Label the Test Cartridge with sample ID. Use the ID area.
- Analyze Afinion™ ACR Control before analyzing patient samples.



3 Procedure for Collecting the Sample

Sampling from a Control Vial

Follow the procedure described below. See page 4 for control testing recommendations.

Sampling from a Urine Cup

- Always use gloves.
- Patient samples stored refrigerated can be used without equilibration to room temperature.
- Mix the sample material well by inverting the urine cup 8–10 times before collecting the sample.
- The sample can be extracted from the urine cup or the cap.

Specimen Collection using the Afinion™ ACR Test Cartridge

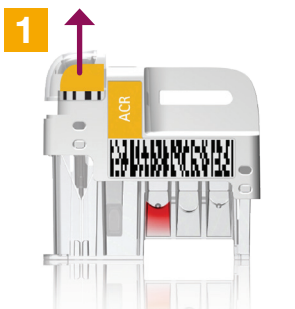

Pull up the sampling device.

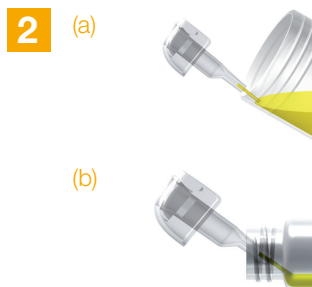

Touch the surface of the patient sample (a) or control (b).

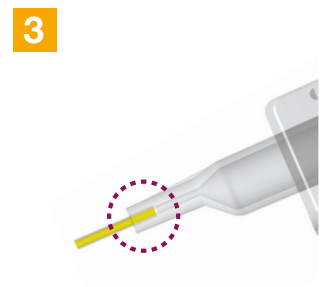

Fill the capillary end to end. It is not possible to overfill.

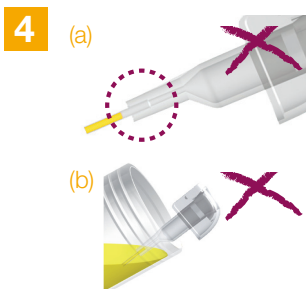

Avoid air bubbles and incomplete filling (a). Avoid sample on the outside of the capillary. Do not dip the neck of the sampling device into the urine cup (b). Do not wipe off.

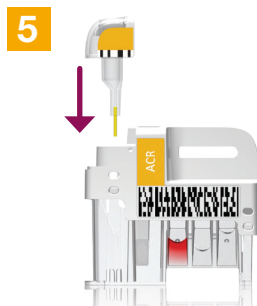

Insert the sampling device immediately.

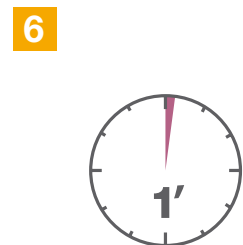

Within 1 minute place the Test Cartridge in the Analyzer.

4 Running Samples on the Analyzer



Patient Sample:
Touch  for patient samples.

Control:
Touch  for controls.



The lid opens automatically.
Insert the Test Cartridge.
The barcode should face left.



Close the lid manually.



Patient Sample:
Touch  and enter patient ID.

Control:
Touch  and enter control ID.

Enter ID during processing.
Touch  to confirm.



Record the result when it appears on the screen.
Touch  to accept.



The lid opens automatically.
Remove and discard the Cartridge.
Close the lid manually.

Information Codes

Important information codes are listed on page 1. Consult the Afinion™ AS100 Analyzer User Manual for information codes not listed on page 1. Follow the actions listed in the User Manual to correct the error.

Verification of Test Results

Consult the Afinion™ ACR Package Insert. See section "Test result reporting".

Verification of Control Results

Compare the results with the values listed on the front of the Afinion™ ACR Control Package Insert.

Technical Support?

Call 1-866-216-9505. This is a toll free number.
Available for use only in the United States of America.

Control Testing

Read the entire Afinion™ ACR Control Package Insert before use.

How often do I have to run controls?

- With each new shipment of ACR kits.
 - With each new lot of ACR kits.
 - At least every 30 days.
 - When training new users.
 - Anytime an unexpected test result is obtained.
-

How should I use the Afinion™ ACR controls?

- The controls can be used directly from the refrigerator without equilibration to room temperature.
 - Mix the control well by inverting the vial 8-10 times before collecting a sample.
 - Analyze the control using the procedures described on page 2 (Specimen Collection) and page 3 (Running Samples on the Analyzer).
 - Compare the test results with the values listed on the front page of the Afinion™ ACR Control Package Insert.
-

What do I do if Afinion™ ACR Control results are not within the acceptable range?

- Do not analyze any patient samples.
- Check the control vial label to make sure it is not expired.
- Ensure that the control has not been used for more than 8 weeks.
- Verify that the controls and test cartridges have been stored correctly.
- Verify that there is no visual sign of bacterial or fungal growth in the control vial.

Correct any procedural error. Re-test the control.

If the control values are still not within acceptable range, repeat the test using a new vial of control. If the control results are still not acceptable, call Technical Support.

Technical Support?

Call 1-866-216-9505. This is a toll free number.
Available for use only in the United States of America.



alere.com

Axis-Shield PoC AS
an Alere company
P.O. Box 6863 Rodelokka
NO-0504 Oslo, Norway
afinion.net